



Oil-Fired

Residential Water Heaters

Featuring Bock's Legendary *Turboflue*®



The heat exchanger with hundreds of turbofans to boost heat transfer -- heating water *faster* with *less* fuel.



- 20 to 113 Gallon Capacities
- 60,000 to 155,000 BTU
- C₂glass® Cobalt-enriched Glass-Lined Tank
- Dual Magnesium Anode Rods to Inhibit Corrosion

The popular Bock® 32E *leads* the industry in Energy Efficiency with a *.63 EF rating* and *170 gallons* first hour delivery.

5-Year limited warranty on residential installations
3-Year limited warranty on commercial installations



This product is available from:

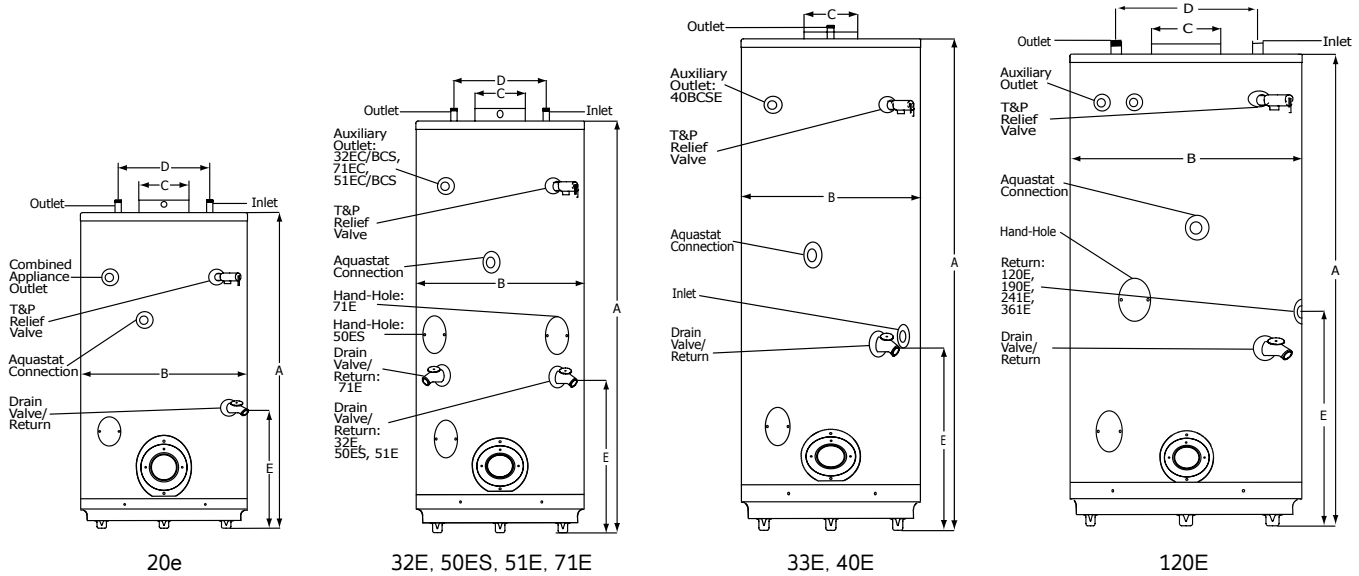

Model	Storage (gal)	Rated Input		Recovery @ Δ 90°F (GPH)	Max. Temp Setting (°F)	Inlet Pipe Dia.	Outlet Pipe Dia.	Return Pipe Dia.	Dimensions					Shipping Weight (lbs)***	
		BTH/HR	GPH						A	B	C	D	E	Standard	ASME
20e	20	60,000	0.43	66	160	3/4"	3/4"	3/4"	38 1/4"	20"	6"	11"	14 3/4"	148	N/A
32E	32	104,000	0.75	114	160	3/4"	3/4"	3/4"	51"	20"	6"	11"	17"	272	N/A
33E	33	104,000	0.75	111	160	3/4"	3/4"	3/4"	43 1/4"	24"	6"	N/A	17 1/4"	278	N/A
40E	40	126,000	0.90	136	160	3/4"	3/4"	1"	61"	20"	6"	N/A	18"	301	N/A
50ES	50	140,000	1.00	151	160**	1"	1 1/2"*	1 1/2"	52"	26"	6"	13 1/2"	18 1/2"	369	N/A
51E	50	152,000	1.10	161	160**	1"	1"	3/4"	59"	24"	6"	11"	18"	330	N/A
71E	68	173,000	1.25	177	160**	1"	1 1/2"*	1 1/2"	66"	26"	6"	13 1/2"	22"	438	N/A
120E	113	155,000	1.10	163	180	1"	2"*	2"	67"	31 1/2"	6"	19"	22"	709	N/A

NOTE: 32E First Hour Rating = 170 Gallons

*Nipple not included
 **Optional setting, contact factory
 ***Weight does not include burner and controls



(on selected models)



T&P Valve: Factory Installed
 Drain Valve: Factory Installed Brass Valve
 Standard Voltage (all): 120V, 60 Hz, 1P
 Pressures (all): Working Pressure, 150 psi; Testing Pressure, 300 psi
 ASHRAE: All Bock Products Meet or Exceed Current ASHRAE Standards.

Warning: Do not install on combustible flooring. Installation should be in accordance with all national and/or local codes. In the absence of local codes, refer to NFPA 31 or ANSI Z.21.10.1.

Caution: The recommended maximum hot water temperature setting for normal residential use is 120°F. Bock recommends a tempering valve or anti-scald valve be installed and used according to the manufacturer's directions to prevent scalding.



www.bockwaterheaters.com
 110 South Dickinson Street, Madison, Wisconsin 53703
 Toll Free 800.794.2491 • Phone 608.257.2225 • Fax 608.257.5304



80014-R Rev 2/11